

Motor Drive for AstroMaster/CG-3 & PowerSeeker/CG-2

Model #93514

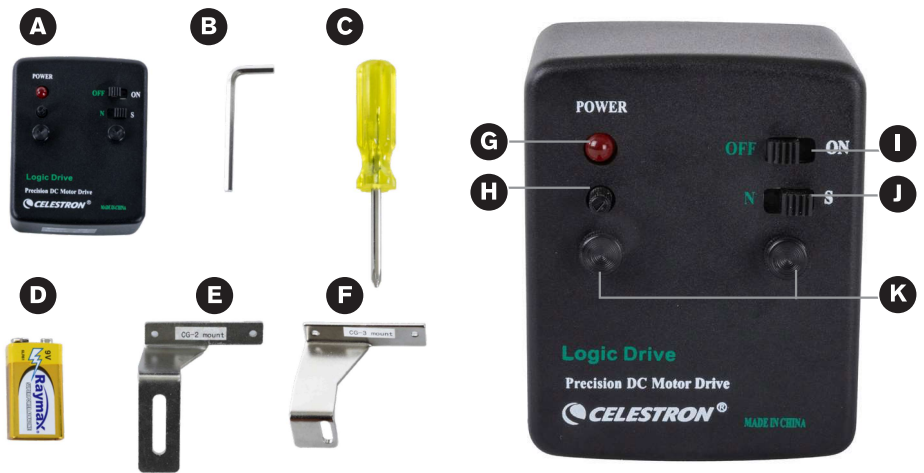

- A.** Motor Drive
- B.** 3/8" Allen Wrench
- C.** Phillips-head Screwdriver
- D.** 9V Battery
- E.** CG-2 Bracket (for PowerSeeker EQ mounts)
- F.** CG-3 Bracket (for AstroMaster EQ mounts, preinstalled on motor drive housing)

- G.** Power Indicator
- H.** Speed Rate Regulator
- I.** On/Off Switch
- J.** North/South Switch
- K.** Mounting Screws

Get ready to enhance your viewing experience with this single-axis motor drive, designed for PowerSeeker/CG-2 and AstroMaster/CG-3 equatorial mounts. Once your mount is polar aligned, this handy motor tracks celestial objects in right ascension (RA), keeping them centered in your eyepiece as they appear to move across the night sky. You may still need to make minor adjustments in declination (Dec), but this drive lets you enjoy longer, more relaxed viewing sessions.

Getting Started: Powering the Motor Drive / Attaching the Bracket

The motor drive runs on a single 9V alkaline battery, which can power the unit for up to 40 hours, depending on the speed setting and outside temperature. First we'll install the battery and, if necessary, replace the mounting bracket.



1 Remove the two cover plate thumb screws (K) from the cover plate of the motor drive.



2 Remove the cover plate to reveal the battery compartment.

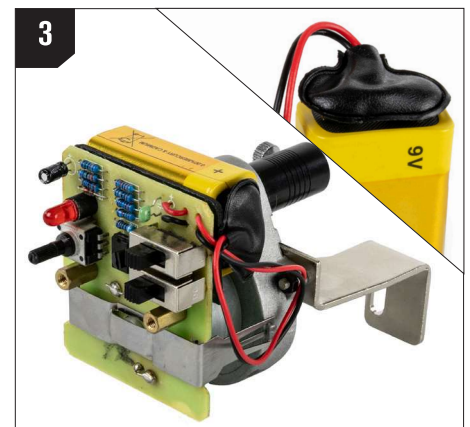

3 Connect the battery to the wire harness inside.



NOTE: The motor drive includes two mounting brackets: a PowerSeeker/CG-2 bracket and an AstroMaster/CG-3 bracket. The CG-3 bracket comes preinstalled on the motor drive housing. If you need the CG-2 bracket, continue to step 4. If not, proceed to step 7.



Before installation, confirm that the bracket is marked with a sticker indicating it is compatible with the CG-2 mount.

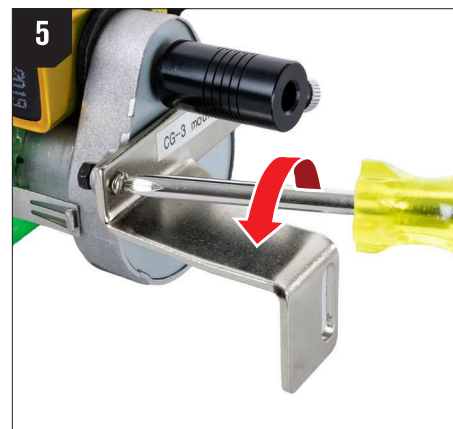

Remove the existing bracket screws and nuts from the motor drive housing. Be careful not to lose the small parts—set the screws and nuts aside in a container for safekeeping.

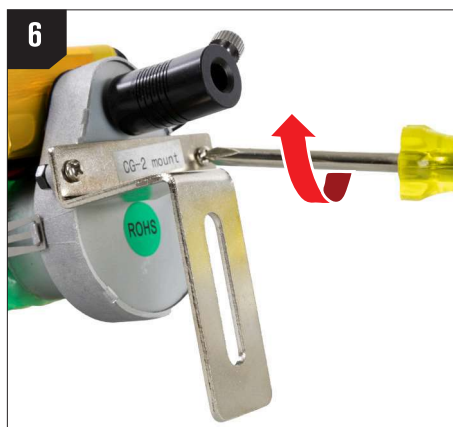

Attach the CG-2 bracket using the same bracket screws and nuts.



Re-attach the cover plate and secure it in place with the cover plate thumb screws.

Installing the Motor Drive on Your Mount

The motor drive attaches to your PowerSeeker/CG-2 or AstroMaster/ CG-3 mount using a bracket and a flexible coupler that connects to the RA slow-motion shaft. Make sure you have the correct bracket mounted to the motor drive.

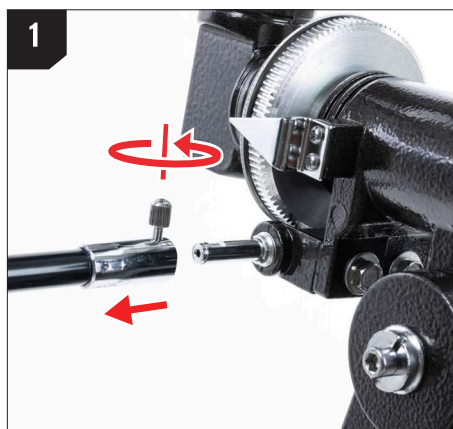

On your mount, remove the RA slow-motion cable from the RA slow-motion shaft.



Slide the open end of the flexible motor coupler over the RA shaft. Make sure that the screw on the coupler is positioned over the flat section of the shaft.



Tighten the coupler screw onto the flat side of the shaft using a flathead screwdriver (not included).

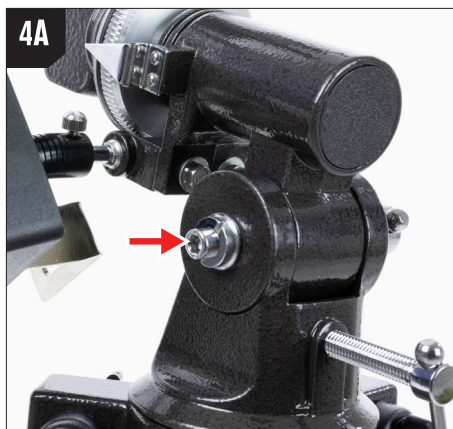

4A Locate the 3/8" Allen screw on the polar shaft and remove it with the included 3/8" Allen wrench. On the CG-2, it's opposite the latitude scale.



4B On the CG-3, it's on the side of the polar housing shaft.



5 Align the slotted hole on the motor bracket with the threaded hole where the Allen screw was. If necessary, pivot the RA worm shaft by rotating the connected motor drive. This will rotate the shaft until the slotted hole in the bracket aligns with the threaded hole on the mount.

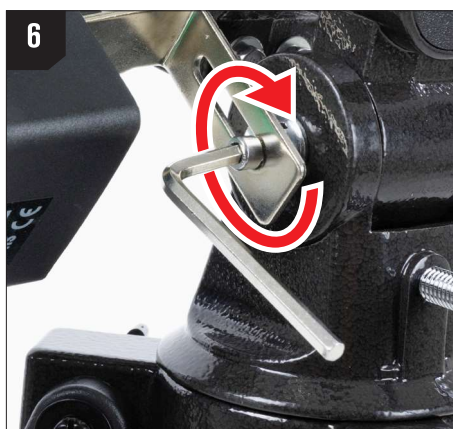

6 Insert the Allen screw through the bracket and into the mount. Tighten it with the 3/8" Allen wrench.

North/South Hemisphere Switch:

The motor drive includes a North/South switch (J.) for use in either hemisphere

- Set it to "N" in the Northern Hemisphere.
- Set it to "S" in the Southern Hemisphere.



Adjusting the Tracking Speed

The drive features a speed rate regulator (H.) that lets you fine tune tracking speed. This is especially useful when observing nonstellar objects like the Moon or Sun, which travel at slightly different rates than the stars.



1 Slide the On/Off switch (I.) to the "On" position. A red LED will illuminate.



2 Turn the speed rate regulator (H.) clockwise to increase speed or counter-clockwise to decrease speed.



IMPORTANT: Never point your telescope at or near the Sun without an approved solar filter on your telescope's objective.

Tracking Celestial Objects with the Motor Drive

For the most accurate tracking, start by roughly polar aligning your mount using Polaris, the North Star.

Polaris sits very close to Earth's North Celestial Pole. It appears nearly fixed in the night sky while other stars seem to rotate around it.

When you polar align your mount, you take advantage of this point of rotation. This way, your mount only needs to track celestial objects along one axis of motion, right ascension, instead of both right ascension and declination.

How to roughly polar align:

- Find Polaris in the Little Dipper constellation. A star chart or astronomy app can help.
- Point your mount's RA axis—the one marked with a latitude scale—toward Polaris.

You don't need perfect alignment to adjust the motor drive. Just get Polaris roughly lined up by sighting along the mount.

How to find the right tracking speed:

1. Select an eyepiece and insert it into the focuser. A crosshair eyepiece helps, but if you only have the two that came with your telescope, choose the one with lower magnification.
2. Center a star near the celestial equator (around 0° declination) in your eyepiece.

3. With the drive turned off, observe which way the star drifts. It will move West across the field of view.
4. If you're using a crosshair eyepiece, rotate it so one of the lines matches the drift direction.
5. Recenter the star in the eyepiece.
6. Turn the drive on and let it track for 1-2 minutes. Then check the star's position:
 - If the star is still centered, the motor speed is correct—no adjustments needed.
 - If the star has drifted West, increase the speed slightly.
 - If the star has drifted East, decrease the speed slightly.

SAFETY INSTRUCTIONS

- There is a risk of explosion if the battery is replaced with an incorrect type.
- The included battery is not rechargeable.
- Only use the battery as originally intended to avoid a short circuit. Connecting the conductive material directly to the battery's positive and negative sides will cause a short circuit.
- Do not use a damaged battery.
- Do not store the battery in an extremely cold or hot environment. Doing so can reduce battery life.
- Remove batteries if drained or if product is to be left unused for a long time.
- When replacing the battery, refer to the instruction manual and ensure the positive and negative sides are oriented correctly.
- Do not put the battery in fire.
- Dispose of the battery according to local regulations.

FCC NOTICE: This device complies with Part 15 of the FCC Rules. Operation is subject to the following two conditions: (1) This device may not cause harmful interference, and (2) this device must accept any interference received, including interference that may cause undesired operation.



Points de collecte sur www.quefairedemesdechets.fr
Privilégiez la réparation ou le don de votre appareil !



Separate waste collection. Check your local municipal guidelines.
Raccolta differenziata. Verifica le disposizioni del tuo Comune.



SOLAR WARNING: Never attempt to view the sun through any telescope.

NEED ASSISTANCE? Contact Celestron Technical Support

celestron.com/pages/technical-support

Product design and specifications are subject to change without prior notification. This product is designed and intended for use by those 14 years of age and older



©2025 Celestron. Celestron and Symbol are trademarks of Celestron, LLC.

All rights reserved. ▪ Celestron.com

US: Celestron, 2835 Columbia Street, Torrance, CA 90503 USA

UK: Celestron Global Ltd., Unit 2 Transigo, Gables Way, Thatcham RG19 4JZ, United Kingdom



www.celestron.com/pages/warranty



Made in China | 05-25